

Standard Practice For Installation of Windows With Integral Mounting Flange in Wood Frame Construction

This practice has been approved as an industry standard by the California Association of Window Manufacturers (CAWM) Technical Committee and by general membership ballot as of June 26, 1995.

1. Scope

- 1.1 This practice covers the installation of windows in residential buildings of no more than four (4) stories in height.
- 1.2 This practice applies to metal and non-metal framed windows when an integral mounting flange is employed for installation.
- 1.3 This practice covers the installation process from pre-installation procedures through post-installation procedures. It does not cover the fabrication or assembly of units whether such fabrication takes place in a factory or at the intended installation site.
- 1.4 This practice covers aspects of installation relating to the effectiveness and durability in service. It does not cover aspects relating to the safety of the person installing the units.
- 1.5 This practice provides minimum requirements that will help to ensure the installation of windows in an effective manner. Actual conditions in buildings vary greatly, and in some cases substantial additional care and precaution will have to be taken.
- 1.6 This practice does not purport to address all of the safety problems associated with its use. It is the responsibility of whomever uses this standard to consult and establish appropriate safety and health practices and determine the applicability of regulatory limitations prior to use.

2. Referenced Documents

2.1 ASTM:

- B 633 "Standard Specification for Electrodeposited Coatings of Zinc on Iron and Steel"
- B 766 "Standard Specification for Electrodeposited Coatings of Cadmium on Steel"
- B 456 "Standard Specification for Electrodeposited Coatings of Copper plus Nickel plus Chromium and Nickel plus Chromium"
- C 755 "Practice for Selection of Vapor Retarder for Thermal Insulation"
- D 779 "Standard Test Method of Water Resistance of Paper, Paperboard, and Other Sheet Materials by the Dry Indicator Method"

2.2 AAMA 800 "Voluntary Specifications and Test Methods for Sealants"

3. Definitions

- 3.1 **Galvanic Corrosion** - A form of deterioration of metal resulting from the electrochemical reaction that occurs when certain dissimilar metals are in contact in the presence of moisture.
- 3.2 **Residential Building** - Any building used or intended primarily for a single or multiple family dwelling.
- 3.3 **Mounting Flange** - A fin projecting from the window frame parallel to the plane of the wall for the purpose of securing the frame to the structure.

4. Significance and Use

- 4.1 This practice recognizes that effectiveness and durability of installed units depend not only on the choice and quality of materials, design, adequacy of assembly, and support system, but also on their proper and workmanlike installation.
- 4.2 Improper installation of units may reduce their effectiveness, lead to excessive air, water and sound leakage, condensation, and may promote the deterioration of wall constructions, windows, doors, and their respective finishes. Additionally, improper installation of metal units may result in accelerated corrosion of metal frames, trim, anchors, fasteners, and finishes.
- 4.3 The application of this practice also requires a working knowledge of applicable Federal, State, and local codes and regulations, specifically, but not limited to required means of egress and requirements for safety glazing. Consult with local building codes prior to installation.
- 4.4 The application of this practice also requires a working knowledge of the tools, equipment, and methods necessary for the installation of windows. It further assumes familiarity with caulking and sealing and with

glass handling procedures, painting where applicable, and an understanding of the fundamentals of residential construction that affect the installation of these units.

5. Procedure

5.1 **Framing Requirements** - The rough framed opening to receive the window shall be sufficiently larger in width and height than the actual frame dimensions of the window. To assure adequate clearance, the framer shall consult the manufacturer's literature for the recommended rough opening dimensions. The framing shall be plumb, square and level. (See Figure 1)

5.2 Protection from Dissimilar Materials

5.2.1 Aluminum products shall be isolated from dissimilar or corrosive materials with a nonconductive coating or sealant material.

5.2.2 All fasteners shall be corrosive resistant, in accordance with ASTM B 633, B 766, or B 456.

5.3 **Flashing Requirements** - Proper flashing and/or sealing is necessary as a secondary barrier to prevent water from entering the wall between the window frame and the adjacent wall materials. Flashing and/or an appropriate method of sealing shall be designed as a part of an overall weather-resistive barrier system. It is **not** the responsibility of the window manufacturer to design or recommend a flashing system appropriate to each job condition.

Note 1 - The responsibility for protecting any flashing material from damage caused by weather, other trades, or vandalism, and properly integrating the flashing system into the weather-resistive barrier for the entire building, will be the responsibility of the general contractor or his designated agent.

5.3.1 **Penetration Flashing Material** - Flashing material shall be barrier coated reinforced and shall provide four (4) hour minimum protection from water penetration when tested in accordance with ASTM D-779. Flashing material shall carry continuous identification.

5.4 Application

5.4.1 One of the two following methods shall be selected as the application to be followed. Once a method is selected, all procedures of that method must be performed in the described sequence. Substitution of a procedure from one method to the other is not permitted.

5.4.1.1 Method A

5.4.1.1.1 A strip of approved flashing material should be at least nine inches wide. Flashing shall be applied in a weatherboard fashion around the full perimeter of the opening.

5.4.1.1.2 Apply the first strip horizontally immediately below the sill, cut it sufficiently long to extend past each side of the window, so that it projects beyond the vertical flashing to be applied later. (See Figure 2)

5.4.1.1.3 Fasten the top edge of the sill flashing to the framing, but do not fasten the lower edge, so the weather resistant building paper applied later may be slipped up and underneath the flashing in weatherboard fashion. (See Figure 2)

5.4.1.1.4 Apply a continuous seal to the backside (interior) of the sill mounting flange, (see Figure 3a). The window shall then be installed in accordance with Section 5.5 installation procedures.

5.4.1.1.5 Next, apply a continuous seal to the exposed mounting flange at the top (head) and sides (jambs) of the installed window. For mechanically joined frames, apply seal at corners the full length of the seam where mounting flanges meet. (See Figure 4a)

5.4.1.1.6 Starting at each jamb, embed the jamb flashing into the seal and fasten in place. Run this flashing beyond the sill flashing and above where the head flashing will intersect. (See Figure 4a)

5.4.1.1.7 Finally, embed the flashing into the sealant on the mounting flange at the window head. Cut this flashing sufficiently long so that it will extend beyond each jamb flashing. Fasten in place. (See Figure 5)

5.4.1.2 Method B

5.4.1.2.1 A strip of approved flashing material should be at least nine inches wide. Flashing shall be applied in a weatherboard fashion around the full perimeter of the opening.

5.4.1.2.2 Apply the first strip horizontally immediately below the sill, cut it sufficiently long to extend past each side of the window, so that it projects beyond the vertical flashing to be applied later. (See Figure 2)

- 5.4.1.2.3 Fasten the top edge of the sill flashing to the framing, but do not fasten the lower edge, so the weather resistant building paper applied later may be slipped up and underneath the flashing in weatherboard fashion. (See Figure 2)
- 5.4.1.2.4 Next, fasten strips of flashing at each vertical edge (jamb) of the opening. Run this flashing beyond the sill flashing and above where the head flashing will intersect. (See Figure 3b)
- 5.4.1.2.5 Apply a continuous seal to the backside (interior) of the mounting flange near the outer edge or a continuous seal to the perimeter of the opening at a point to assure contact with the backside (interior) of the mounting flange. (See Figure 4b)

NOTE 2 - Caution must be taken to avoid disrupting the continuous seal.

- 5.4.1.2.6 The window shall then be installed in accordance with Section 5.5 installation procedures.
- 5.4.1.2.7 For mechanically joined frames, apply seal at corners the full length of the seam where mounting flanges meet.
- 5.4.1.2.8 Next, apply a continuous seal at the top (head) mounting flange and embed the bottom of the head flashing over the sealant and the mounting flange. Cut this flashing sufficiently long so that it will extend beyond each jamb flashing. Fasten in place. (See Figure 5)

5.5 Installation

- 5.5.1 Depending on the size and weight of the window, shim blocks may be required under the sill to maintain straight and level condition and to prevent rotation. Consult manufacturer's recommendations.
- 5.5.2 Shim and adjust the window as necessary to achieve a plumb, square and level condition, as well as an even reveal around the frame opening, securing it the full perimeter with the equivalent of 6d fasteners on a maximum 16-inch centers. Hinged and pivoted windows may require additional fasteners located near the hinge or pivot points. For certain windows it may be appropriate to fasten the head in a manner to allow for possible deflection.
- 5.5.3 In each direction from all corners there must be a fastener within 10 inches, but no closer than 3 inches, to prevent frame distortion or fracture of joint seals.
- 5.5.4 In all cases consult manufacturer's instructions for any special procedures or applications.

NOTE 3 - If any damage to window frame joint seals is observed during installation, it must be repaired by the installer.

- 5.5.5 Where weather-resistant building paper, insulating board, or other materials *by other trades* may constitute the primary weather barrier behind the exterior wall finish (i.e. stucco, masonry, siding, etc.), Owner/General Contractor is responsible to ensure that the weather barrier is continuous by effectively sealing the material to the window frame. (See Figure 6)

5.6 Sealant Requirements

- 5.6.1 Sealing/caulking required between the window and the flashing can be accomplished with caulking conforming to AAMA 800, or use sealant recommended and approved by the sealant manufacturer.
- 5.6.2 Some exterior wall finishes require additional sealing between the perimeter of the window frame and adjacent finish wall material. Owner/General Contractor is responsible for identifying the need for any additional sealant which will be applied *by others*. Such sealant shall be elastomeric material, compatible with window framing and adjacent wall materials. (See Figure 6)

5.7 Finish And Sealant Protection

- 5.7.1 Caution shall be used to avoid damage to windows during and after installation. Prior to installation, store windows in a near vertical position in a clean area, free of circulating dirt or debris and protected from exposure to weather elements.
- 5.7.2 Field-applied protective coatings can damage window sealants and gaskets and are not recommended. Contact the window manufacturer before applying any such coatings.
- 5.7.3 Masking tapes shall not be used on window surfaces as they may cause damage when they are removed.
- 5.7.4 Stucco or concrete left to cure on frames and glass will damage these surfaces. Remove and clean all such materials from surfaces before any curing action takes place.
- 5.7.5 Glass and frame surfaces exposed to leaching water from new concrete or stucco must be rinsed immediately with clear water to prevent permanent damage.

Fig. 4a. Jamb Flashing (Method 'A')

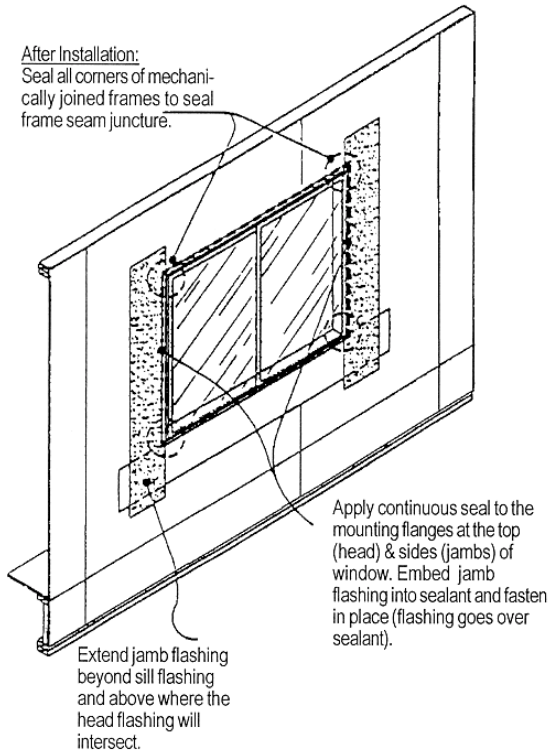

Fig. 4b. Window Installation (Method 'B')

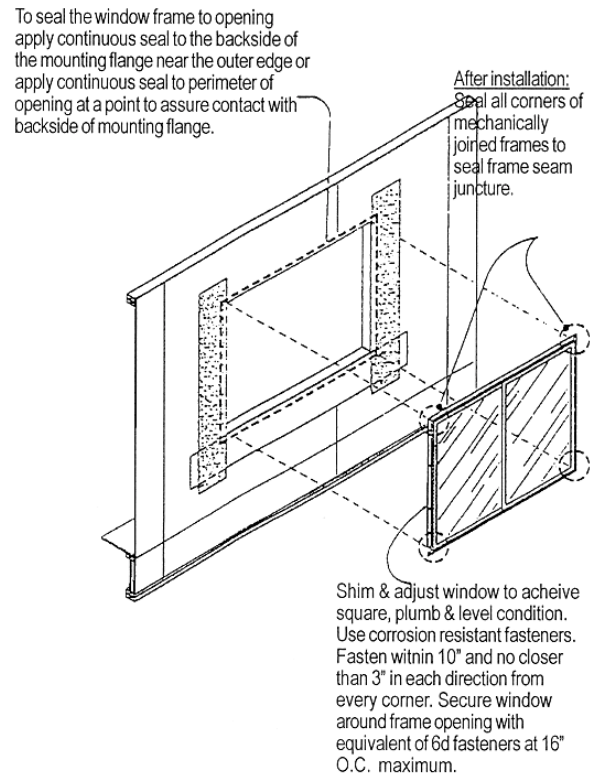

Fig. 5. Head Flashing

Method A

Embed bottom of the head flashing against the previously applied sealant. (Flashing goes over sealant.) Extend head flashing beyond each jamb flashing. Fasten in place.

Method B

Apply continuous seal along top (head) mounting flange. Embed bottom of head flashing against sealant (flashing goes over sealant), extend head flashing beyond each jamb flashing. Fasten in place.

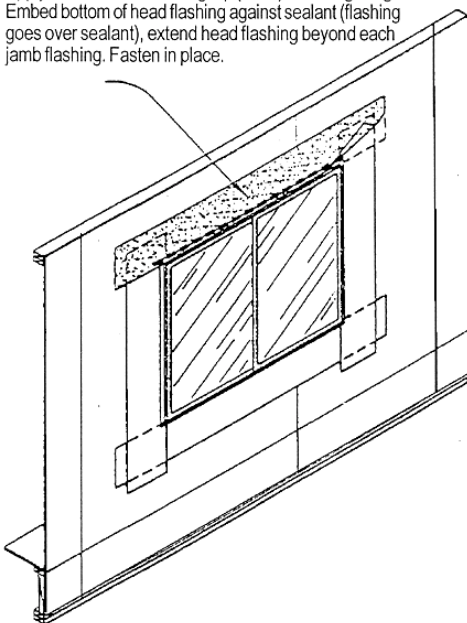

Fig. 6. Primary Weather Barrier Application by Others

Where recommended as part of exterior wall finish system install building paper apply weatherboard fashion starting from bottom to top of sill.

By other trades

Install building paper insulation board or other materials over head flashing and over top of narrow head flange of window frame.

